

NC-155 RECEIVER

Instruction Manual



NATIONAL RADIO COMPANY



**Reworked by
PAØPGA**

This manual was downloaded from **BAMA's**
boatanchor site <http://bama.sbc.edu>



IMPORTANT

READ CAREFULLY BEFORE TURNING ON YOUR NEW NC-155

The following instructions are designed to allow you to immediately set up your new NC-155 for proper operation using AM, SSB, or CW receiving techniques. They are ONLY intended to provide a quick reference for proper set-up procedure, and we strongly recommend that you study the instruction manual carefully as soon as possible.

AM OPERATION

1. Set BAND switch to desired band.
2. Turn STBY-REC toggle switch to REC.
3. Rotate FUNCTION knob (lower left of Main Tuning knob) to AM. Note that there are two AM positions, the left for operation without AGC (Automatic Volume Control), and the right providing AGC. When the right-hand AM position is being used, the S Meter is operative and indicates relative signal strength.
4. Turn SELECTIVITY knob (lower right of Main Tuning knob) to 5 kc or 3 kc.
5. Turn RF GAIN knob fully clockwise.
6. Turn AUDIO GAIN knob clockwise to apply power to the receiver. Volume may be adjusted to a comfortable listening level.
7. Peak ANTENNA knob for maximum background noise in the absence of a signal.
8. Atmospheric noise or man-made electrical interference may be alleviated by rotating FUNCTION knob to ANL (Automatic Noise Limiter). There are two ANL positions, one for ANL action with AGC, the other for ANL action without AGC.

SSB OPERATION

1. Set BAND switch to desired band.
2. Turn STBY-REC toggle switch to REC.
3. Rotate FUNCTION knob (lower left of Main Tuning knob) to SSB-CW. Note that there are two SSB-CW positions, the left allowing operation without AGC (Automatic Volume Control) and the right providing AGC. When the right-hand SSB-CW position is used, the S-meter is operative and indicates relative signal strength.
4. Turn BFO knob to LSB or USB to select proper side-

band (usually LSB on 80- and 40-meters, USB on the 20-, 15-, and 10-meter bands).

5. Turn the SELECTIVITY knob (lower right of Main Tuning knob) to 3 kc.
6. Rotate RF GAIN knob fully clockwise.
7. Turn AUDIO GAIN knob clockwise to apply power to the receiver. As soon as the receiver warms up, volume may be adjusted to a comfortable listening level.
8. Peak ANTENNA knob for maximum background noise in the absence of a signal.

CW OPERATION

1. Set BAND switch to desired band.
2. Turn STBY-REC toggle switch to REC.
3. Rotate FUNCTION knob (lower left of Main Tuning knob) to SSB-CW, AGC off.
4. Turn SELECTIVITY knob to .6 kc (600 cycles).
5. Turn BFO knob to approximately 1:30 o'clock.
6. Rotate RF GAIN knob to an initial setting of 3 o'clock. Receiver volume is adjusted with this control following step 8.
7. Turn AUDIO GAIN control clockwise to apply power to the receiver; set it at 12 o'clock. As soon as the receiver warms up, volume may be adjusted with RFG knob to a comfortable listening level. The AUDIO GAIN knob should remain at approximately 12 o'clock since the excellent product detector in the NC-155 provides ample listening volume.
8. Peak Antenna knob for maximum background noise in the absence of a signal.
9. Adjust BFO knob, if necessary, for most pleasing CW pitch.
10. CW operation with automatic gain control may be obtained by following the instructions for SSB OPERATION.



SPECIFICATIONS

Frequency Ranges

6 meter band (50.0 - 54.0 mc)
 10 meter band (28.0 - 29.7 mc)
 15 meter band (21.0 - 21.5 mc)
 20 meter band (14.0 - 14.4 mc)
 40 meter band (7.0 - 7.3 mc)
 80 meter band (3.5 - 4.0 mc)

Tuning Control

60:1 step down ratio with pinch type drive and 5:1 panel vernier for smooth inertia tuning.

Calibration

Accessory 1 mc crystal calibrator and exclusive National lateral dial adjustment provide for extreme calibration accuracy.

Intermediate Frequencies

1st IF — 2,215 kc,
 2nd IF — 230 kc

Image Rejection

Double conversion superheterodyne circuit provides optimum image and intermediate frequency rejection on all bands.

Sensitivity

Better than 1.0 microvolt for 1 watt output,
 10 db signal to noise ratio.

Selectivity

Special National "Ferrite Filter" provides the following bandwidths:
 VERY SHARP — 600 cycles
 MEDIUM — 3.0 kc
 BROAD — 5.0 kc

Reception of Single Sideband Signals

Special National "Ferrite Filter" and Calibrated BFO control provide selection of upper and lower sideband with special triode heterodyne detector and separate carrier reinsertion.

Reception of CW Signals

Heterodyne detector circuit with separate beat frequency oscillator.

Automatic Gain Control

Operates in AM, CW and SSB positions or may be disabled for manual control.

Noise Limiter

Automatic type, self-adjusting to various signal levels.

Signal Strength Meter

Calibrated in S units from "S-1" to "S-9" (at 50 microvolt input) and "10 DB" to "60 DB" above S-9. Operates on AM, CW or SSB reception.

Audio Power Output

3.0 watts, better than 1.5 watts at 10% distortion.

Antenna Input

50 ohm, unbalanced on all bands.

Output Circuit

3.2 ohm for loudspeaker. Separate front panel headphone jack.

Control Circuits

Standby-Receive switch with separate set of contacts for external control available at rear of receiver. Rear panel circuit is closed in the Standby position only, or terminals on accessory socket provide for external shunting of STBY-REC switch.

Power Line Requirements

105-125 volts A.C. 50-60 cycles 75 watts

Front Panel Controls

Tuning		Selectivity switch
Radio frequency gain		5.0 kc
Beat frequency oscillator		3.0 kc
Antenna trimmer		0.6 kc
Bandswitch		
Mode switch	ANL	} AGC on
	AM	
	CW-SSB	} AGC off
	CW-SSB	
	AM	} Phone jack
	ANL	
		Standby-Receive switch
		Audio gain control
		Combination Calibration set and switch

Flip Foot

Unique "Flip Foot" on receiver and matching speaker for maximum operating convenience.

Dimensions

8 $\frac{3}{8}$ " high 15 $\frac{3}{8}$ " wide 9" deep
 Shipping Weight 28 lbs.





DESCRIPTION AND OPERATION

The following paragraphs briefly describe the recommended operating procedure for the National NC-155 Receiver, and also include a brief circuit description. Paragraphs in standard type face concern operating instructions only; those in bold face type describe the circuits.

The National NC-155 receiver is designed to match an unbalanced 70 ohm antenna and transmission line. Individual antenna coils are used on each band. The impedance match is obtained by use of a small primary coupling winding on the antenna coil, with the exception that on the 6 meter band the impedance match is obtained by means of a tap on the antenna coil.

THE ANTENNA

The rear apron of the NC-155 receiver contains a two-terminal antenna strip suitably marked A and G. The simplest antenna is a single long wire illustrated below. When an antenna of this type is used, a suitable ground connection is recommended for best results. Generally speaking, an antenna between 15 feet and 40 feet long should provide ample signal pick-up for most of the amateur bands in use. When the receiver is to be used predominantly on any one band, better results can always be obtained with one of the many types of tuned antennas. The common doublet or half-wave antenna is illustrated below, and may be connected to the receiver antenna terminals by connecting one of the lead wires to the antenna terminal and the other to the ground terminal; although, more satisfactory results will generally be obtained if a suitable balanced-to-unbalanced transformer type coupling is used. Many other types of antenna configurations are available and beneficial under various reception conditions. The subject of antennas, and the matching of antennas to receivers, is in itself a major study. The owner of the NC-155 should consult one of the excellent references published by the American Radio Relay League and other organizations. In all cases where an external exposed antenna is used, suitable consideration should be given to lightning protection for the safety of the operator and the equipment.

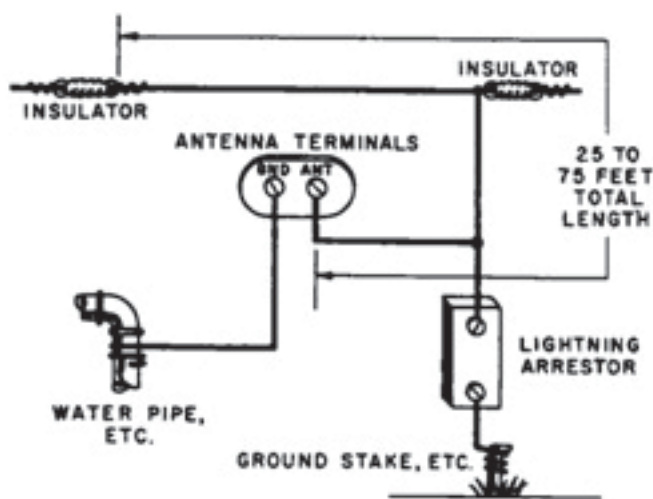

SINGLE WIRE ANTENNA

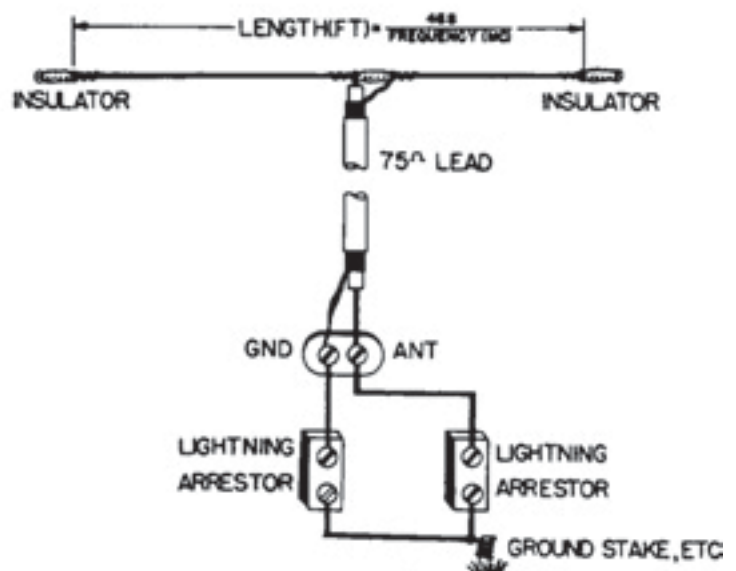

DOUBLET ANTENNA

The proper antenna coil is selected by means of the BAND switch that switches the primary and secondary windings of the desired coil, thereby connecting the desired winding to the receiver circuit.

BAND SWITCH

BAND switching is actuated by means of the BAND switch on the front panel. This switch is simply placed in the desired BAND position as indicated by the various amateur band markings: 80, 40, 20, 15, 10, and 6. When the BAND switch has been set for the band desired, the corresponding dial scale carrying the identical band marking is used to indicate the frequency of receiver tuning.

The secondary of the antenna coil is used as a tuned circuit to achieve selectivity in the antenna stage of the receiver. This coil is tuned by means of the main tuning capacitor C1, and the antenna trimmer. It should be noted that the stator plates of the main tuning capacitor are split into two sections with one or both sections being used, depending on the band selected, thus providing for use of the entire dial on each amateur band.

ANTENNA TRIMMER

The ANTENNA trimmer control is used to make a final adjustment of the tuned circuit to insure maximum gain on



or various types of antennas will have some effect on the antenna stage. The use of the antenna trimmer compensates the receiver to match the type which may be connected to it. It is normally set the ANTENNA control only once for each frequency. This is best accomplished by tuning the antenna trimmer from any signal and adjusting the ANTENNA control for maximum background noise in the speaker or earphone. Normally, it should not be necessary to repeak the antenna trimmer for different settings on the same antenna; however, if the BAND switch is used to change use, the antenna trimmer must be repeaked for each selected frequency.

The signal appearing across the tuned circuit of the antenna is coupled through a capacitor to the grid of the first converter tube which operates as the RF stage of the receiver. Automatic gain control (AGC) voltage is applied to this grid to adjust the gain (of the first converter) to a level suitable for the strength of the signal received.

The signal from the plate circuit of the RF stage is coupled through the choke L1; and the RF signal is coupled to the primary of the mixer coil through capacitor C7. As in the case of the antenna stage, this coupling of the mixer coil is an untuned circuit. The antenna trimmer, 15-, 10-, and 6-meter bands, no primary capacitor is used, and the signal from the plate of the first converter is coupled directly to the tuned interstage coil. The selectivity switch, once again, performs the function of switching the right coil for the band in use. The second converter mixer coil is tuned to further add to the selectivity of the receiver. This tuning is accomplished by means of the main tuning capacitor, alignment capacitors C8 through C13 and, in some instances, an additional fixed capacitor used to obtain proper alignment for the frequency band. Again, as in the antenna stage circuit, the main tuning capacitor is split into two sections with one or both sections being used, depending on the band selected. The signal appearing across the mixer tuned circuit is coupled directly to the grid of the 6BE6 first converter tube.

The grounded-plate Hartley oscillator circuit is used for the 230 kc signal conversion to the first IF frequency. This oscillator is a part of the 6BE6 first converter tube. The proper oscillator coil is selected by the selectivity switch, and the oscillator tank circuit is tuned by the main tuning capacitor and the alignment trimmer to obtain a high degree of stability in the oscillator. A special zero temperature coefficient ceramic capacitor C6 is used to form the predominant portion of the oscillator circuit. In addition, a small negative temperature compensating capacitor C14 is used to compensate the positive temperature coefficient of the coils. The selection of parts results in temperature stability

experienced operator. The oscillator frequency is always 2215 kc above the signal frequency to which the receiver is tuned, thus generating a 2215 kc first IF signal. This signal is fed from the plate of the 6BE6 first converter to a conventional double tuned IF transformer which serves as the interstage coupling between the first and second converters. Signal coupling is accomplished by means of the mutual inductance between the primary and secondary of this interstage transformer, and the resulting signal is applied to the signal grid of the 6BE6 second converter tube. The selectivity of this first IF circuit provides excellent secondary IF image rejection and at the same time is high enough in frequency to provide excellent primary image rejection which results from the tuned antenna and mixer circuits. The second converter oscillator is a grounded-plate Hartley circuit using the screen of the 6BE6 converter as the grounded plate. This second IF oscillator frequency is set at 2445 kc which beats with the 2215 kc signal to produce a 230 kc IF output.

The 230 kc IF signal is coupled from the plate of the 6BE6 second converter tube to the National Ferrite Filter. The Ferrite Filter circuit uses two tuned circuits with the "Q" of the individual coils running approximately 500. The two tuned circuits are impedance-coupled one to the other with the selectivity switch performing the function of changing the coupling impedance and damping to achieve variations of bandwidths from the narrow 600 cycle position to the wide 5 kc position. In addition to changing the degree of coupling and damping, small tuning capacitors are switched to center all pass bands thus eliminating the need for retuning when the selectivity is changed.

SELECTIVITY SWITCH

The SELECTIVITY switch of the NC-155 receiver provides for three degrees of selectivity. The SELECTIVITY switch is marked with positions for 5 kc, 3 kc, and 0.6 kc. The degree of selectivity used depends largely on the mode of operation desired, and signal conditions. The 5 kc position would normally correspond to the highest receiver fidelity. However, under conditions of extreme signal interference, it is often desirable to reduce the bandwidth of the receiver and sacrifice fidelity in favor of less interference by using the 3 kc position. When CW reception is desired, further bandwidth reduction is effective and useful, and it is recommended that the 600 cycle (0.6 kc) position be used. In normal AM operation, the 3 kc or 5 kc bandwidth positions provide an adequate degree of selectivity. For CW operation, as stated above, the 600 cycle bandwidth is recommended; and for single sideband operation, the 3 kc bandwidth is recommended.



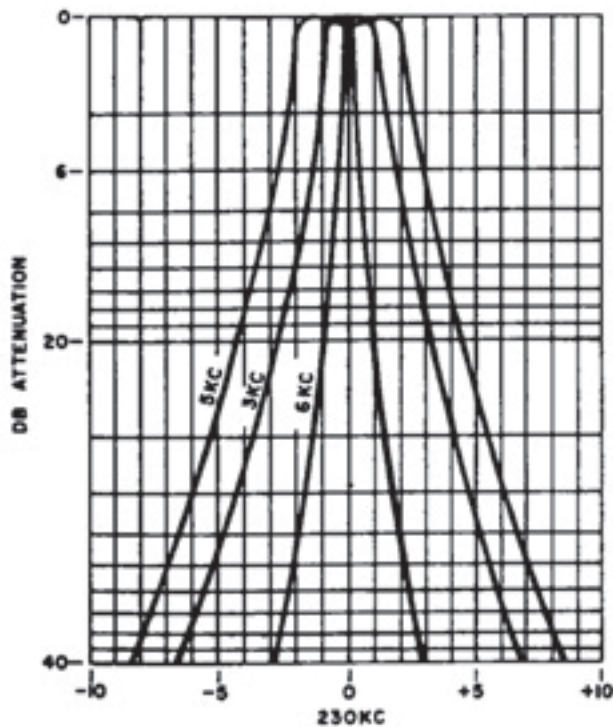

SELECTIVITY CURVES

The signal appearing across the secondary winding of the Ferrite Filter is applied to the grid of the first 6BA6 IF stage which operates as a conventional signal amplifier at 230 kc. The 230 kc signal from the plate of the first IF stage is coupled to the grid of the second 6BA6 IF stage through a conventional double-tuned transformer.

The cathode of both 6BA6 stages and the 6BZ6 RF stage are returned to the chassis by way of the RF gain bus and the RF gain control. As the resistance of the RF gain control is increased, additional cathode bias is built up across it, thus reducing the over-all receiver gain. Small resistors are used in the individual cathode leads in order to keep the RF and IF tubes in rating when the RF gain control is set at maximum.

RF GAIN

The sensitivity of the receiver is adjusted by means of the RF GAIN control which controls the cathode bias on the RF and both 6BA6 IF stages. When the control is rotated to its maximum counterclockwise position, the sensitivity of the receiver will be reduced to the point where no signal can be received. Rotating the control clockwise will increase sensitivity until maximum is reached at the full clockwise position. During CW or single sideband reception, the RF GAIN knob may be used freely as a means of

sensitivity adjustment as the receiver is tuned from signal to signal. For AM reception, the RF GAIN control should be set to a comfortable sensitivity level and allowed to remain in this position. Adjustment of the RF GAIN control will have some effect on the S Meter reading. For proper indication of the S Meter it is recommended that the receiver be detuned from any signal and the RF GAIN control advanced until the background noise reaches a level sufficient to cause a reading of approximately 1 unit on the S Meter. This setting of the RF GAIN control should then suffice for all normal AM signal conditions.

The signal appearing at the plate of the last 6BA6 IF stage is coupled to the AM detector by means of a conventional, inductively-coupled, double-tuned IF transformer operating at the second IF frequency at 230 kc. The diode at pin 6 of the 6T8 tube is used as a conventional AM detector. Resistors R25 and R26 comprise the detector load.

The AGC signal is derived from the high end of the detector load with resistors R24, R11, and capacitor C38 functioning as an AGC filter to remove the audio signal appearing across the detector load. This AGC signal is applied directly to the grid of the first 6BA6 IF tube through the secondary winding of the Ferrite Filter. The AGC signal is also applied through R1 to the grid of the 6BZ6 rf stage.

The audio signal appearing across R26, a portion of the detector load, is coupled directly to the mode switch or to the plate of the separate diode portion of the 6T8 detector-audio tube. The cathode of this diode is supplied with a filtered dc signal also derived from the detector load. The dc signal is equal in level to the peak audio amplitude, thereby keeping the diode conducting for all normal modulation. Should a noise pulse occur, the high negative noise spike across the audio portion of the detector load takes the plate of the noise-limiter negative with respect to its cathode, and conduction ceases, thereby effectively removing the noise peak from further signal circuits. This noise peak does not appear at the cathode of the noise limiter due to the filtering action of resistor R27 and capacitor C52. The audio output occurring on the cathode of the noise limiter circuit is also coupled to the FUNCTION switch. In the event of CW or single sideband reception, the FUNCTION switch grounds the cathode of one-half of the 12AX7 which serves as a beat frequency oscillator using a grounded-cathode Hartley oscillator circuit.

BFO

The BFO control is used to adjust the frequency of the beat-frequency oscillator which correspondingly varies the pitch of the generated audio tone. When receiving single sideband signals, the BFO should be set to the USB or LSB mark depending on the sideband desired (generally LSB on 80- and 40-meters and USB on 20-, 15-, and 10-meters). This setting will properly position the BFO relative to the IF passband for SSB reception.



from this setting. When receiving CW signals, a mid-position setting of the beat oscillator would correspond to a condition wherein the maximum IF selectivity occurs at zero beat with the incoming signal and no audio tone would be observed at the point of maximum signal reception. It is therefore necessary to slightly detune the beat oscillator in either direction to provide a suitable audio tone which is comfortable to the operator and to obtain maximum sensitivity. During CW reception it is often convenient to adjust the beat oscillator to phase an undesired signal to zero beat, thus eliminating it as an audible interfering signal.

The signal from the beat oscillator is coupled through a small capacitor to the grid of the other 12AX7 triode which serves as a triode product detector. The IF signal from the plate of the second IF tube is coupled through a small capacitor to the cathode of the product detector and the desired product appears in the plate circuit. The undesired mixer products are filtered out, and the audio signal is coupled to the FUNCTION switch through an RF filter composed of resistor R23 and capacitor C49.

FUNCTION SWITCH

The FUNCTION switch allows selection of the AM signal or the output of the automatic noise limiter (ANL) with AGC either operating or not operating, and also allows selection of the output from the product detector for single sideband (SSB) or CW reception. In normal operation, the noise limiter may be used at will, depending on incoming noise level and operating convenience. In the event that CW or single sideband reception is desired, it is essential that the mode switch be placed in the CW-SSB position. The ANL, AM and CW-SSB positions appear twice on the mode switch corresponding to operation with AGC either on or off for each receiving mode.

The S meter is connected between the plates of the two 6BA6 IF stages and, as was mentioned above, the AGC is applied to the first of these IF stages with the result that as signal amplitude increases, conduction through the first IF stage is decreased, but conduction through the last IF stage remains constant, thereby changing the potential difference between the plates which causes a current flow and an effective meter reading. The zero-adjust is accomplished by adjusting the S Meter Zero Adjust control to establish zero potential difference across the meter under conditions of no incoming signal.

S METER

Normal adjustment of the S Meter is readily accomplished by increasing the RF GAIN control to maximum sensitivity which corresponds to its extreme clockwise setting. The receiver should be tuned so that only background noise is heard and the antenna trimmer peaked. The S Meter Zero Adjust control should then be adjusted for a reading of approximately S1 on the incoming noise level which will assure proper S Meter reading. When properly adjusted, an

microvolts of signal at the antenna terminals.

The desired audio signal output from the FUNCTION switch is then coupled to the AUDIO GAIN control and in turn, to the grid of the first audio amplifier which is the triode section of the 6T8 tube.

AUDIO GAIN

The AUDIO GAIN control is used to adjust the speaker or earphone level to comfortable listening volume. It is important not to confuse the function of the AUDIO GAIN control with the function of the RF GAIN control which controls the over-all receiver sensitivity. Normally, with the RF GAIN control advanced to provide proper S Meter reading, all additional variation of listening level is accomplished with the AUDIO GAIN control. In the event of operation with AGC off, the RF GAIN control is sometimes used as the master sensitivity control and the AUDIO GAIN control is left set in a predetermined position. Proper balance between the two controls under this condition is normally a matter of individual operating preference.

The output from the plate of the first audio amplifier is impedance-coupled directly to the grid of the 6CW5 audio output stage. The amplified audio is taken from the plate of the audio output stage through the audio transformer to the speaker terminals. The secondary winding of the audio transformer is designed to match a 3.2-ohm speaker such as the matching NTS-3 table speaker assembly. The secondary of the audio transformer is also connected through a shorting type phone jack which is so wired that upon the insertion of a standard phone plug the loud speaker circuit will be broken and the speaker silenced.

PHONE JACK

The head phone jack is available on the front panel and will accept any normal 2 circuit phone plug. There is no DC voltage associated with the head phone circuit. Because of the low impedance of the audio transformer secondary, almost any type of head phone may be used with completely satisfactory results.

An accessory socket is provided on the rear apron of the NC-155 receiver and is wired to accept the XCU-109 one megacycle crystal calibrator. Power to this accessory socket is provided through the front panel CALIBRATE switch. The signal from this accessory calibrator is coupled to the antenna terminals of the receiver to provide a strong CW signal at every 1 mc point on the dial.

CALIBRATE SWITCH

To properly calibrate the dial, with the accessory XCU-109 calibrator, the RF GAIN control should be advanced to normal receiver sensitivity and the front panel CALIBRATE switch should be rotated to the ON position. The calibrator signal may then be tuned at any even 1 mc point on the dial scale corresponding to the band in use. It is sometimes convenient to use the CW mode reception in



... to see how to the calibrator signal and make identification of the signal less difficult. After an appropriate calibrator signal has been tuned, the operator may observe that this signal does not correspond exactly to the 1 mc calibration point of the dial scale. In this event, the CALIBRATE switch knob may be moved from side to side thus moving the entire dial scale to place the calibrated mark directly over the tuning pointer. Once this is achieved, the calibrator may be turned off and an accurate calibration is assured.

The power supply of the NC-155 receiver is a conventional transformer-type power supply which employs a 5Y3GT tube in a full-wave rectifier circuit with a suitable power supply filter and a shunt feed to an OB2 voltage regulator tube. The OB2 is used to regulate the plate supply voltage to the high frequency or first converter oscillator and the beat frequency oscillator. A STBY-REC (standby-receive) switch is provided in the 145 volt supply bus in order to remove power from the plate and screens of most tubes for STBY operation. Terminals 4 and 5 of the accessory socket are wired in parallel with the STBY-REC switch for remote control of the receiver.

STBY-REC

The STBY-REC switch is a two-position toggle switch which may be set at STBY to mute the receiver, or placed in the REC position for normal operation. An auxiliary pair of terminals on this switch is connected to the rear relay terminals in such a manner that the rear relay terminals are effectively open-circuited in the REC position and short-circuited in the STBY position. This allows control of an external relay circuit by means of the STBY-REC switch. If the STBY-REC switch is placed in the STBY position

the receiver may be activated by externally shorting terminals 4 and 5 of the receiver.

The mechanical structure of the NC-155 employs a solid $\frac{1}{8}$ " panel for extreme mechanical rigidity and stability. A separate bottom cover and cabinet top are employed for ease in servicing and the National Radio Company patented Flip-Foot has been added for operator convenience.

CABINET

The Flip-Foot of the NC-155 receiver may be easily elevated into the raised position, or dropped back to the flat position for maximum operating ease. To elevate the Flip-Foot, simply lift the forward portion of the cabinet and reach under and pull the rear edge of the Flip-Foot down and forward until it reaches its forward or upright position. To remove the top half of the cabinet for normal service, it is necessary only to remove the two screws on the lower forward corner of each side of the cabinet and the two screws at the lower outside corners of the back. It is then possible to remove the cabinet top by simply lifting and springing the front top lip of the cabinet free from the retaining clips attached to the panel. The cabinet is simply replaced by reversing this procedure, taking care to engage the slots in the forward lip of the cabinet into the two clips welded to the rear of the top section of the panel. The bottom cover of the receiver may be removed independently by removing the two rear mounting feet which serve as combination mounting feet and retaining screws, and by removing the four retaining screws. After removing these screws, the bottom cover may be slipped to the rear and removed from under the Flip-Foot to allow free access to the wiring of the receiver.



AM SIGNAL STRENGTH METER AND TUNING INDICATOR. WHEN RFG IS ADVANCED FOR AN S-1 READING ON BACKGROUND NOISE AN "S-9" READING IS APPROXIMATELY EQUIVALENT TO A 50 MICROVOLT INPUT AT THE ANTENNA TERMINALS. THE S METER DOES NOT OPERATE WHEN THE MODE SWITCH IS IN ANY OF THE "AGC" POSITIONS.

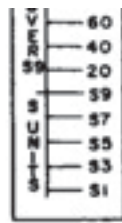

R.F. GAIN



ADJUSTS THE RECEIVER RF AND IF GAIN. USUALLY USED AS A VOLUME CONTROL IN "AGC OFF" POSITIONS OF THE MODE SWITCH. THIS CONTROL ALSO REDUCES THE RECEIVER GAIN AND THE S METER SENSITIVITY IN THE "AGC ON" POSITIONS OF THE MODE SWITCH.

ANTENNA

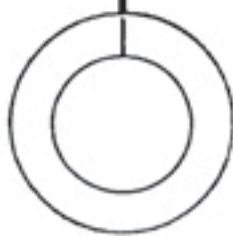

ADJUSTS RECEIVER INPUT CIRCUIT FOR BEST ANTENNA MATCH ON EACH BAND AS INDICATED BY MAXIMUM SIGNAL STRENGTH. THIS CONTROL SHOULD BE ADJUSTED EACH TIME A DIFFERENT BAND IS SELECTED.

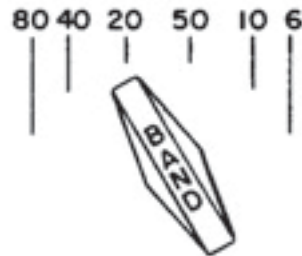

SELECTS DESIRED AMATEUR BAND. THE DIAL SCALE WHICH CORRESPONDS TO THE SELECTED BAND IS USED TO INDICATE THE FREQUENCY OF RECEIVER TUNING.

FUNCTION



SELECTS THE DESIRED RECEPTION MODE, WHICH MAY BE EITHER STRAIGHT AM OR AM WITH AUTOMATIC NOISE LIMITER OR CW-SINGLE SIDEBAND RECEPTION. LEFT HAND POSITIONS CORRESPOND TO AGC OFF AND RIGHT HAND POSITIONS CORRESPOND TO AGC ON.

THIS CONTROL SELECTS FREQUENCY AS INDICATED

NC-155 CONTR



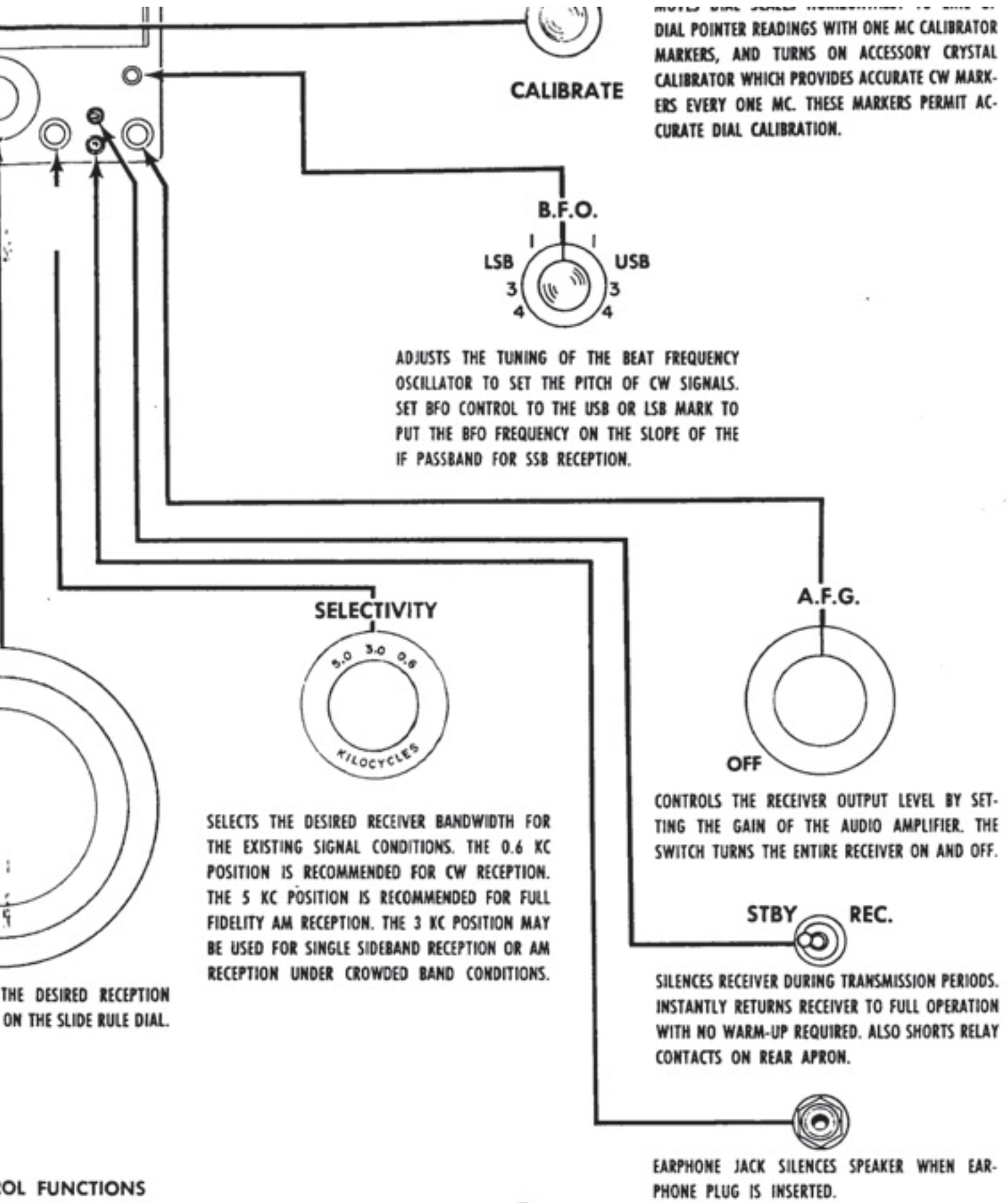

MOVES THE CALIBRATE POINTERS TO THE DIAL POINTER READINGS WITH ONE MC CALIBRATOR MARKERS, AND TURNS ON ACCESSORY CRYSTAL CALIBRATOR WHICH PROVIDES ACCURATE CW MARKERS EVERY ONE MC. THESE MARKERS PERMIT ACCURATE DIAL CALIBRATION.



ALIGNMENT INSTRUCTIONS

The NC-155 receiver has been carefully aligned at the factory by specially trained and experienced personnel using precision equipment. Alignment of the receiver should not be attempted until all other possible causes of faulty operation have been investigated. Alignment should be made only by persons familiar with communications receivers and experienced in their alignment. Refer to illustration for location of all alignment adjustments.

EQUIPMENT REQUIRED:

1. Signal generator covering 450 kc to 55 mc.
2. Vacuum tube voltmeter (VTVM)
3. Output meter. The AC scale of the VTVM can be used.
4. Tuning Wand — General Cement No. 8278 or equivalent.
5. K Tran Tool — General Cement No. 5097 or equivalent.

INITIAL CONTROL SETTINGS:

Bandswitch.....As indicated in chart.
 RF and AF Gain.....Fully Clockwise.
 Mode Switch.....AM with AGC off.
 Selectivity.....As indicated in chart.
 Tuning.....Plates half-meshed unless otherwise indicated.
 Antenna Trimmer.....Mid range.
 Lateral Dial Adjustment.....Mid range.
 Calibrator.....Off.

ALIGNMENT PROCEDURE:

230 KC IF ALIGNMENT

Signal Generator Connections	Signal Generator Frequency	Bandswitch Setting	Output Connections	Selectivity Setting	Remarks
High side directly to pin 7 of 2nd 6BE6. Low side to chassis.	230 kc (unmodulated)	80 M	VTVM DC Probe to junction of R24, R25, and C51. Low side to chassis.	0.6 kc	Adjust FL1, FL2 for maximum indication. Rock generator to insure both cores tune through maximum. Peak both sides of T12 and T14. Maintain approximately 2V reading on VTVM.

2215 KC IF ALIGNMENT

Signal Generator Connections	Signal Generator Frequency	Bandswitch Setting	Output Connections	Selectivity Setting	Remarks
High side directly to mixer section of tuning gang.	2215 kc (unmodulated)	80 M	VTVM DC probe to junction of R24, R25, and C51. Low side to chassis.	0.6 kc	Tune L11 to approximately 2445 kc for maximum response. Check to insure image is at 2675 kc. Peak top and bottom of T11. Maintain approximately 2V reading on VTVM.



BFO ALIGNMENT

Signal Generator Connections	Signal Generator Frequency	Bandswitch Setting	Output Connections	Selectivity Setting	Remarks
High side directly to pin 7 of 2nd 6BE6. Low side to chassis.	230 kc (unmodulated)	80 M	VTVM DC probe to junction of R24, R25, and C51. Low side to chassis.	0.6 kc	Rock generator for maximum output. Maintain approximately 2V reading on VTVM. Set mode switch to CW-SSB. Set BFO knob to center mark on panel. Loosen set screw and adjust L13 to zero beat with screwdriver through hole in shield. Then tighten set screw and return mode switch to AM-AGC OFF position.

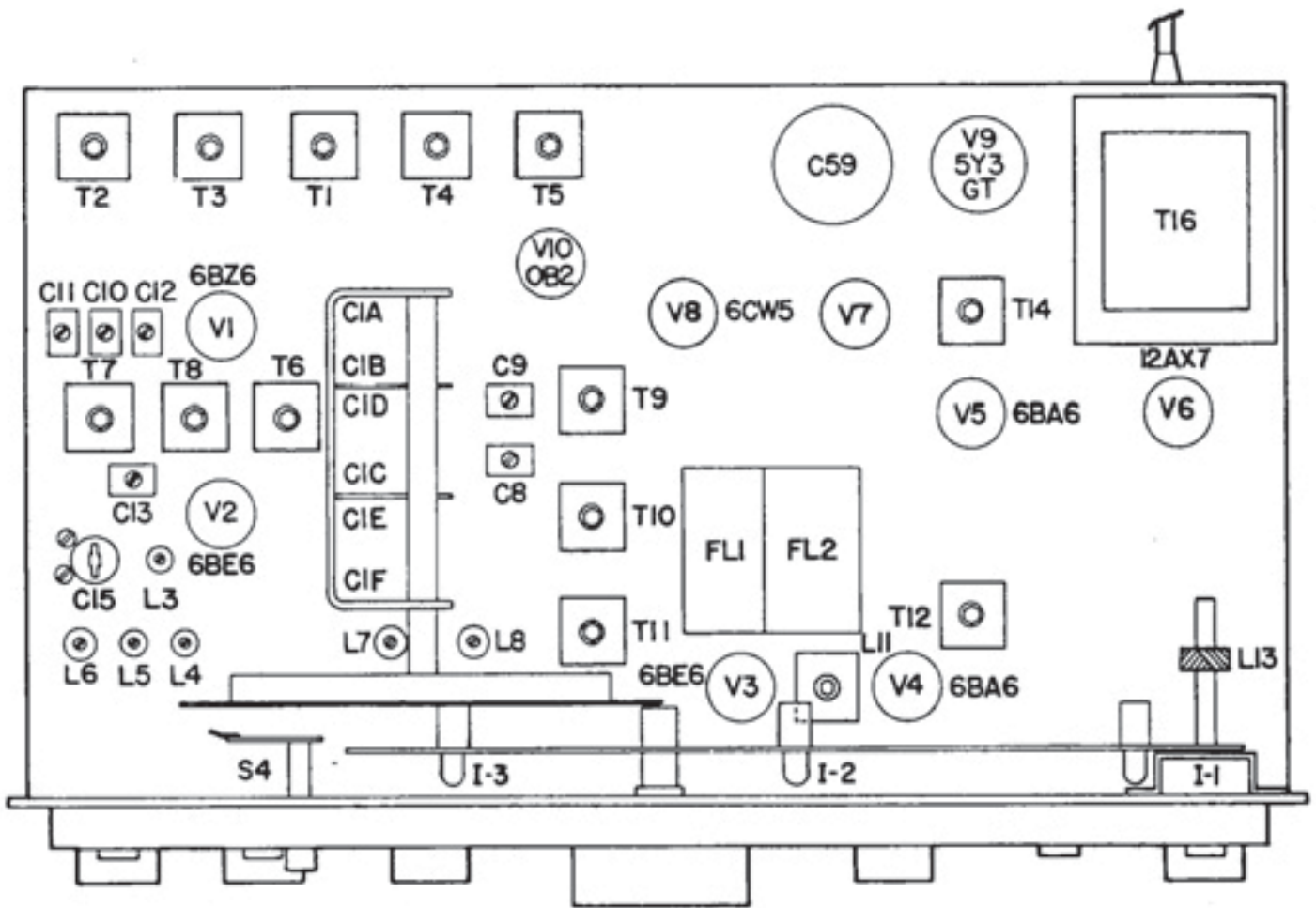

TOP VIEW



ALL READILY AVAILABLE RESISTORS AND CAPACITORS ARE OMITTED FROM THE FOLLOWING PARTS LIST, BUT ARE COMPLETELY IDENTIFIED ON THE SCHEMATIC.

	PART NAME	PART NO.		PART NAME	PART NO.
I1, I3	Panel Lamp	NPL47		Bottom Cover Painted	D50462-2
V1	6BZ6 Tube	6BZ6		Cabinet Assy Complete	D50418-5
V2, V3	6BE6 Tube	6BE6		Rails, Dial	B50496
V4, V5	6BA6 Tube	6BA6		Panel Terminal (Relay)	A12616
V7	6T8 Tube	6T8		Panel Terminal (Speaker)	A12617
V6	12A7 Tube	12A7		Panel Terminal (Antenna)	E265-28
V8	6CW5 Tube	6CW5		Socket 7 pin Black Phenolic	B27669-3
V10	OB2 Tube	OB2		Socket 9 pin Black Phenolic	B27668-1
V9	5Y3-GT Tube	5Y3-GT		Socket Octal	B27674-1
R17	Resistor 330 ohm 10W ±10%	B17436-1	T15	Transformer - Output	B22025-2
C69	Capacitor - Mica 170mmf ±1%	NCS-20-171-F-5	C1	Main Tuning Capacitor	C50529-2
C25, C27	Capacitor - Mica 3900mmf ±1%	NCS-20-392-F-5	C15	Disc Drive	A50125
C16	Capacitor - Ceramic 100mmf ±2% Special ±10 PPM	A50113	T16	Trimmer Ceramicon	B19783-2
L1	RF Choke Encapsulated	A50206-1	C59	Transformer - Power	C50087
	Line Cord	B50473-1	C8-C12	Capacitor - Electrolytic	C19458-5
	Front Panel - Complete	D50492-3	R20	Capacitor - Mica Trimmer	A50137
	Coil Mtg - Bushing	A50107	R29	Potentiometer - S Meter	B50466
	Clamp, BFO Coil	A50148-52	S2	Potentiometer - AF Gain	B50089
	Slug Iron, BFO	B50188-4	S3	Switch - Selectivity	B50431
L13	Coil BFO	B50470	R15	Switch - Mode	B50490
	Spring Slug Screw	A50421	J1	Potentiometer - RF Gain	B50092
	Window - Complete	B50493-2	S6	Phone Jack	A50263
	Pointer Rail	B50110-3		Switch Toggle	B50205
	Window Light Shield	C50498-4	S1	RF Shield	C50093
S7	Switch Calibrate	B50578	C2	Switch Band	C50094
	S Meter	C50441-1		Variable Capacitor - Antenna	B50095
	Pointer	B50130		Coupling Spring	B25000
	Dial Cord Assy	B19347	T12, T14	Transformer - IF Output	B50103
	Bushing Panel	50598	L11	2nd Oscillator Coil	B50443
	Bushing Nut	A50117-4	FL1, FL2	Ferrite Filter	B50529
	Pinch and Vernier Assy	B50599	T11	Transformer - 2215 kc	B50510
	Bowed Ring (Snap)	A50282-4	T5	Coil - Antenna 80 M	B50167
	Bezel Front Panel	B50132-1	T4	Coil - Antenna 40 M	B50161
	Knob - BFO	B50518-2	T3	Coil - Antenna 20 M	B50168
	Knob - RFG or Depth	B50519-2	T2	Coil - Antenna 15 M	B50169
	Set Screw No. 6 X 3/8	SS-6-R-C-6-X	T1	Coil - Antenna 10 M	B50170
	Set Screw No. 6 X 1/8	SS-6-R-C-2-Z	T10	Transformer rf 80 M	B50171
	Knobs - AFG and Ant.	D22500-X42-X-4AC	T9	Transformer rf 40 M	B50172
	Knob - Mode	D22500-X42-X-4U	T8	Transformer rf 20 M	B50173
	Knob - Selectivity	D22500-X42-X-4Z	T7	Transformer rf 15 M	B50174
	Knob - Band	C11916-6	T6	Transformer rf 10 M	B50175
	Knob Assy. Main Tuning	B13599-5	L8	Mounting Clip	A19405
	Knob, Calibrate and Lateral	B50586-Z	L7	Coil Osc. 80 M	B50197
	Sockets, Light	B50300	L6	Coil Osc. 40 M	B50196
	Flip Foot, Silver	B50145-2	L5	Coil Osc. 20 M	B50195
	Rivets	SR-125-B-14-N	L4	Coil Osc. 15 M	B50194
	Push-on Tinnerman	A50284-1	L3	Coil Osc. 10 M	B50193
	Rubber Foot	A50281-2	L2	Coil Osc. 6 M	B50192
			L9	Coil Antenna 6 M	B50190
			L10	Coil rf 6 M	B50200



DIAL CORD INSTALLATION AS VIEWED FROM REAR OF SET WITH TUNING CAPACITOR AT MAXIMUM MESH

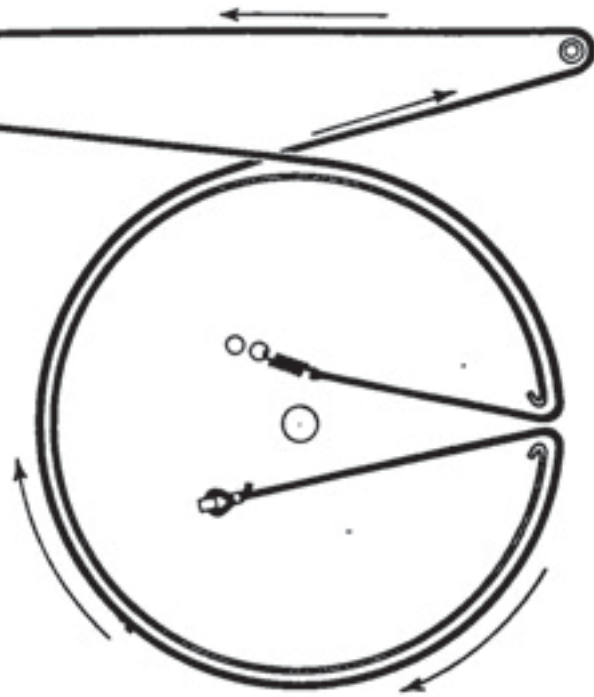

DIAL CORD ASSEMBLY

STANDARD FORM WARRANTY
of
NATIONAL RADIO COMPANY, INC.
A Wholly owned subsidiary of NATIONAL COMPANY, INC.

This equipment is warranted to be free from defective material and workmanship and repair or replacement will be made of any part which under normal installation, use and service discloses defect, provided the unit is delivered by the owner to the manufacturer or through the authorized radio dealer or wholesaler from whom purchased, intact, for examination, with all transportation charges prepaid to the factory, within ninety days from the date of sale to original purchaser, and provided that such examination discloses in the manufacturer's judgment that it is thus defective.

Damages arising out of the breach of warranty to the owner shall be limited to the return of the goods and repayment of the purchase price or to the repair or replacement of non-conforming goods or parts at the election of the manufacturer.

This warranty does not extend to any radio products which have been subjected to misuse, neglect, accident, incorrect wiring, improper installation, or to use in violation

of instructions furnished by the manufacturer, nor does it extend to units which have been repaired or altered outside of the factory, nor to cases where the serial number thereof has been removed, defaced or changed, nor to accessories used therewith of other manufacture.

Any part of a unit approved for remedy or exchange hereunder will be remedied or exchanged by the authorized radio dealer or wholesaler without charge to the owner.

This warranty is in lieu of all other warranties expressed or implied and no representative or person is authorized to assume for the manufacturer any other liability in connection with the sale of their radio products.

National Radio Company, Inc. reserves the right to make any change in design or to make addition to, or improvements in, its products without imposing any obligations upon itself to install them in its products previously manufactured.

NATIONAL RADIO COMPANY, INC.
Melrose 76, Mass.



Reworked by
PAØPGA

This manual was downloaded from BAMA's
boatanchor site <http://bama.sbc.edu>



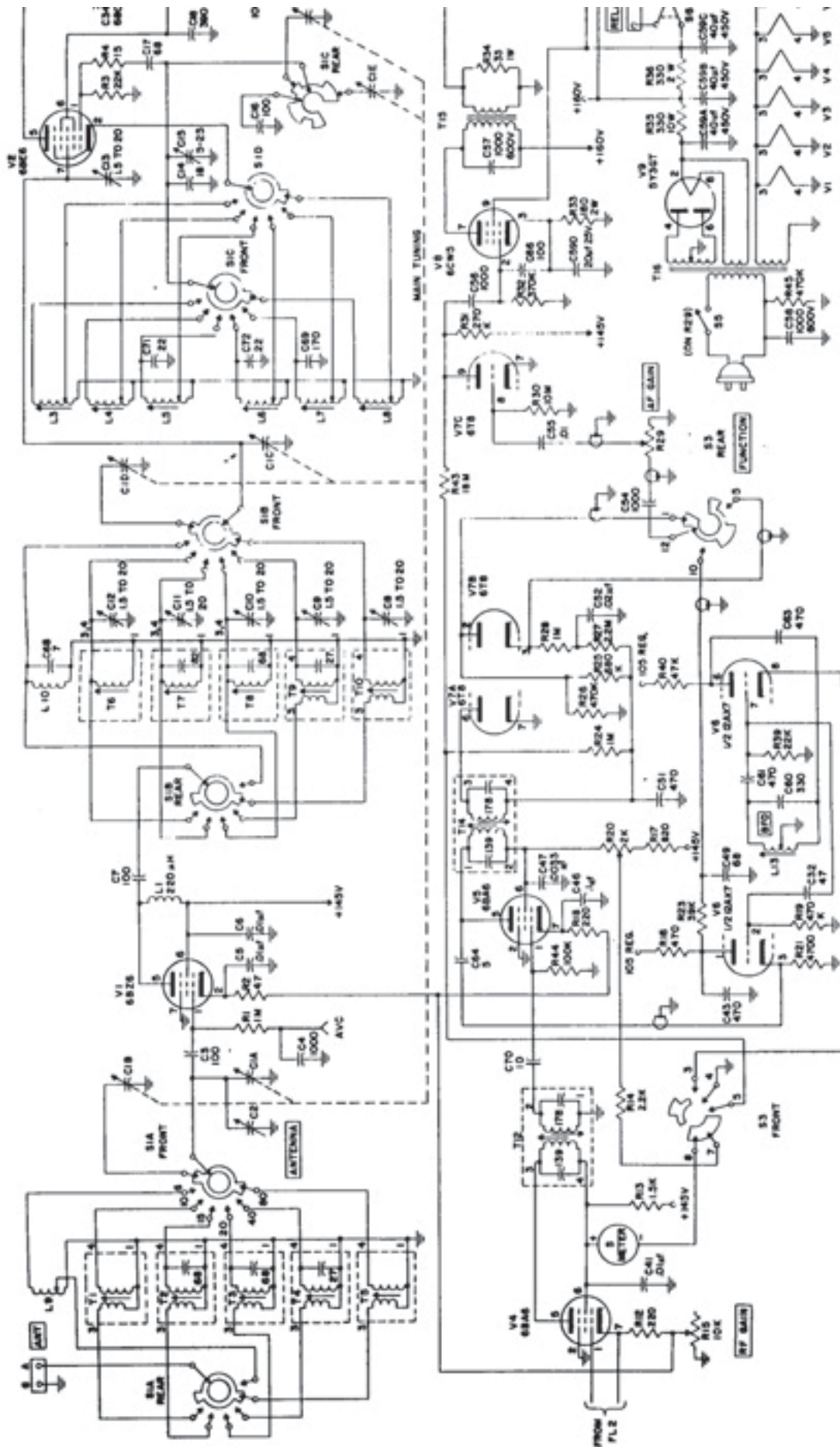



K4XL's BAMA

This manual is provided free of charge from the "Boatanchor Manual Archive", as a service to the Boatanchor community. It was uploaded by someone who wanted to help you repair and maintain your equipment.

If you paid anyone other than **BAMA** for this manual, you paid someone who is making a profit from the free labor of others, without asking their permission

You may pass on copies of this manual to anyone who needs it. But do it without charge.

Thousands of files are available without charge from **BAMA**. Visit us at: <http://bama.sbc.edu>

**Real radio's have tubes!
Keep them glowing !!**

File credits:

**Glenn Zook
K9STH**

This manual is reworked and converted from a BAMA loose pages file to a easy to print manual in PDF format by:

PAØPGA

